

Tolerances Moulding

Overview

Viking Extrusions' house tolerances for mouldings are laid down in our quality manual as follows:

Standard

ISO 3302-1:2014 Rubber Tolerances for products

Key

- X direction of pressure
- 1 upper half of mould
- 2 moulded part
- 3 flash
- 4 lower half of mould

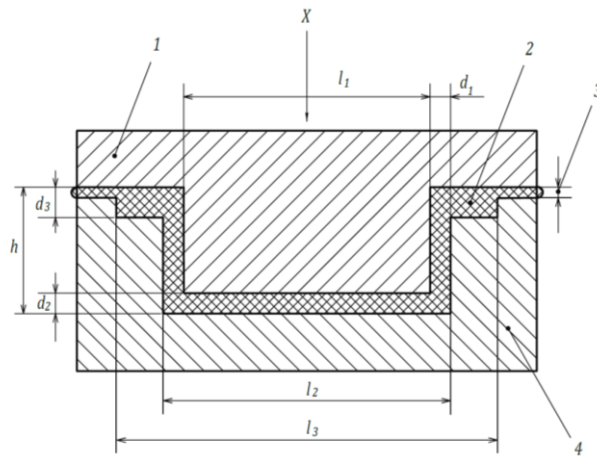

Table 1 – Tolerances on mouldings

Nominal dimension		Class M1		Class M2		Class M3		Class M4
Above	Up to and including	F±	C±	F±	C±	F±	C±	F± and C±
0	4.0	0.08	0.10	0.10	0.15	0.25	0.40	0.50
4.0	6.3	0.10	0.12	0.15	0.20			
6.3	10	0.10	0.15	0.20	0.20	0.30	0.50	0.70
10	16	0.15	0.20	0.20	0.25	0.40	0.60	0.80
16	25	0.20	0.20	0.25	0.35	0.50	0.80	1.00
25	40	0.20	0.25	0.35	0.40	0.60	1.00	1.30
40	63	0.25	0.35	0.40	0.50	0.80	1.30	1.60
63	100	0.35	0.40	0.50	0.70	1.00	1.60	2.00
100	160	0.40	0.50	0.70	0.80	1.30	2.00	2.50
160	-	0.3%	0.4%	0.5%	0.7%	0.8%	1.3%	1.5%

All values in millimetres

Viking Extrusions Ltd

4 Ivy Arch Road, Worthing
West Sussex, BN14 8BX
Tel: +44 (0) 1903 205 532
Fax: +44 (0) 1903 205 534
www.vikingextrusions.co.uk



Certificate Number: FM40230